

The Barrel & Chiller Guide





“This—Sh*t—Works”

Wim Hof

- Welcome 04
- How it works 06
- Need to know 07
- Parts overview 08, 09
- Getting set up 10, 11, 12, 13
- Using the control panel 14
- Keeping the water clean 17
- Cleaning the filters and changing the water 18
- Cleaning the filters without draining the water 19
- Using the ozone cleaning function 20
- Fault codes and solutions 21
- Maintaining the Barrel 22
- Chiller technical data and power consumption 23
- Support 24

Welcome

The cold is both brutal and spiritual. A fierce stressor, yet a valuable teacher. It can be without mercy, and—if you let it—will reward you with the warmest of hugs. It's why we have an unstoppable quest to help people like you to get their cold on.

We're here to support people, like you, in their every day journey towards building a stronger mind and a healthier body. As Wim Hof says, "This—Sh*t—Works".

Power-up your day

The Barrel & Chiller – Where Art meets Tech

Aged over decades maturing Scotland's beloved Whisky's - and now up-cycled and reimagined to take you on a journey into cold water immersion. Every oak barrel is restored by expert coopers in the Speyside Valley before being handed to us for finishing, these barrels are steeped in their own history which is why every one is stripped back, refurbished and deep cleaned before being resined and oiled. This ensures it's perfectly water tight and has locked-in the original wood colour and uniqueness. No oak barrel is the same, they each bear their own subtle colouring and markings.



How it works



Rapid cooling & heating

The chiller that connects to our barrel is capable of cooling at 3°C an hour and once it reaches target temperature it will maintain it for you. It will cool to between 3 and 5°C and can also heat the water to 40°C should you want it to do that. There's a simple touch screen to control the chiller or you can connect it via our app to remotely set and monitor temperatures.

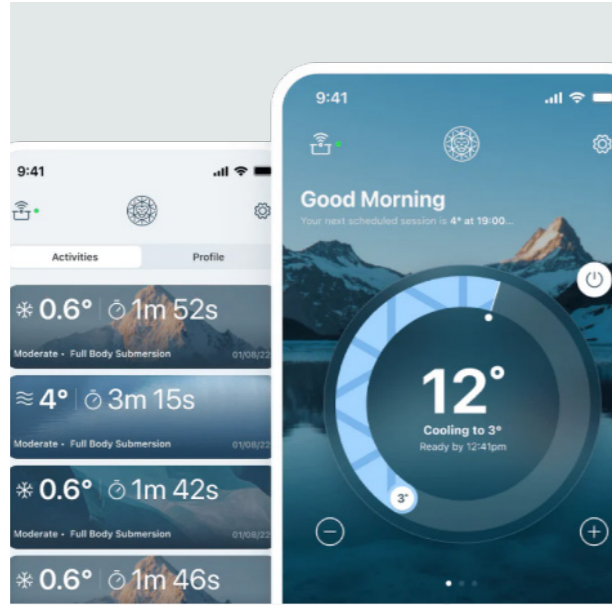

Automated and connected

Our barrels are designed to ensure you can just say focussed on your immersion. Using our companion app you can schedule your barrel to be ready when you want it to be, bringing efficiency to temperature management. On top of that, receive maintenance reminders to ensure your water is always crystal clear.



Maintenance

The barrel uses a simple paper filter and an inbuilt ozonator to keep the water clean and free of any nasties. To ensure your water stays clean for as long as possible we'd always recommend a quick shower before jumping in!

Need to know

- The weight of the Barrels when full is over 600Kg and will need a stable base that can withstand this weight.
- The Barrel will need to settle into its environment - leave to stand for a day or two or you may experience leakage. This is normal. The oak barrel is over 50 years old and the wood will expand and contract. This means that the resin on the inside of the barrel will stretch and a leak may occur. After a day or two, when the wood has settled into its environment the resin will self heal and become watertight.
- To empty the barrel you will need a submersible pump - we recommend a puddle pump.
- Leave adequate space for ventilation near the grilles to allow airflow to the chiller unit.
- Do not plug into an extension cable - this is a fire hazard.
- When using the Barrel & Chiller switch the power off to the chiller - this is essential in case the chiller is going through an ozone cycle. Ozone dissipates within minutes of being released but it's safest to switch it off to ensure this.

Parts Overview

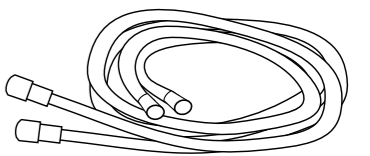
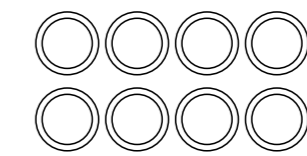
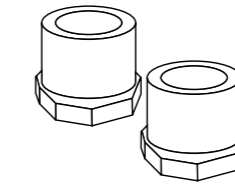
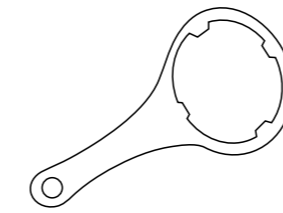
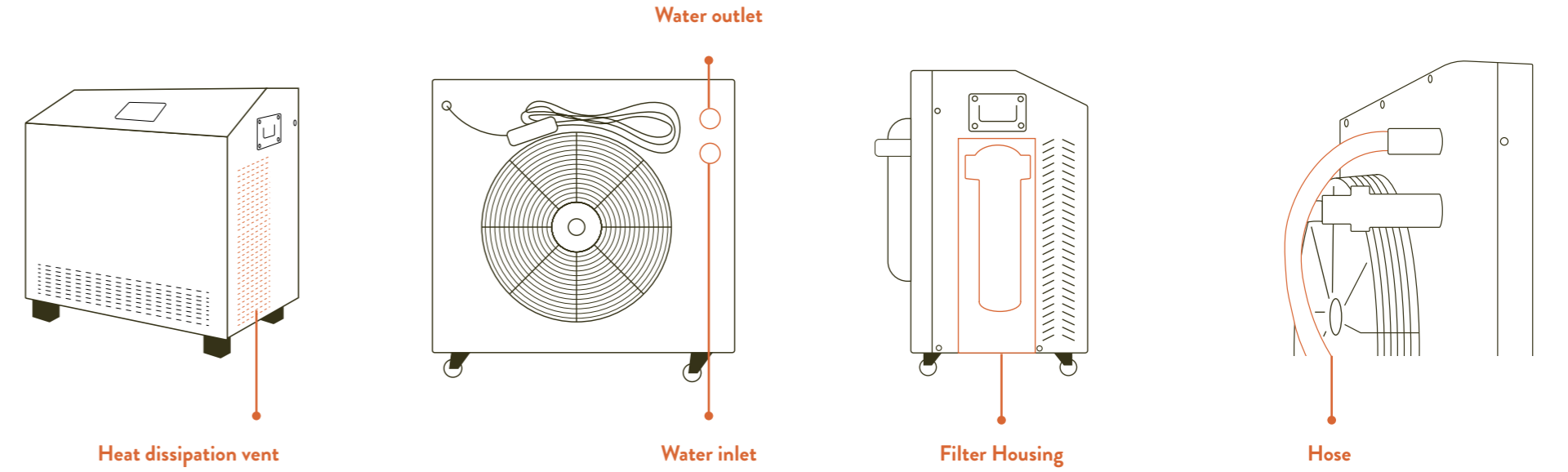
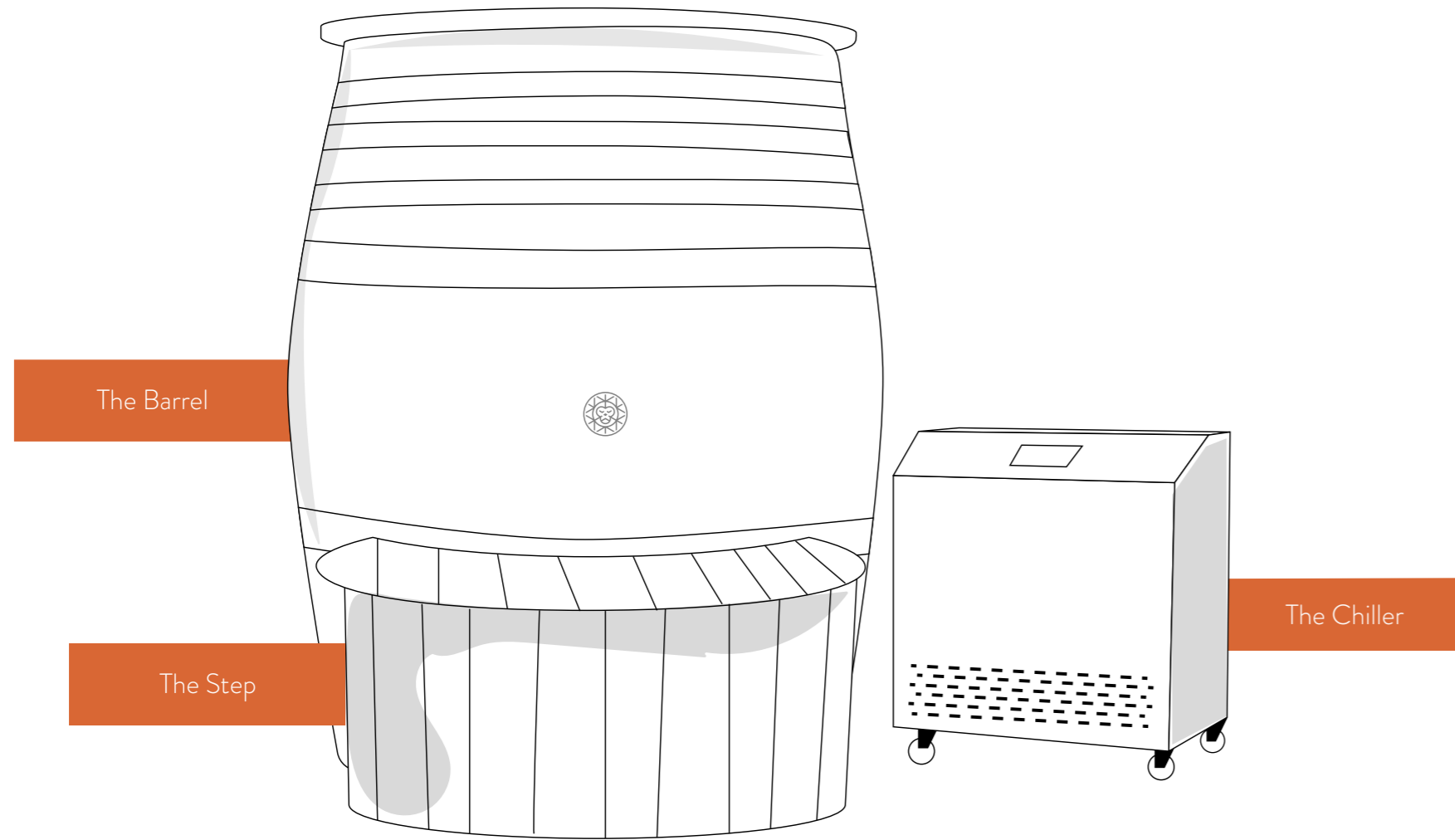

Filter housing Spanner

Quick Connectors X2

Spare O rings

Hose x2

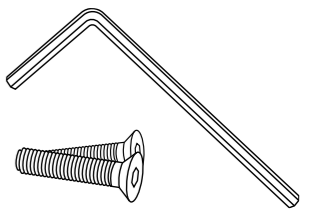
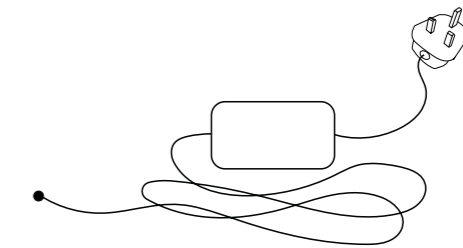
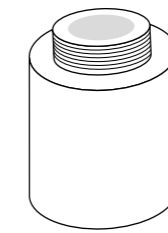
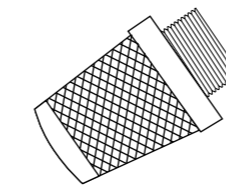

Hose Filter

Hose Adapter

Light Pack

Screws and allen key for bench



Getting Set Up

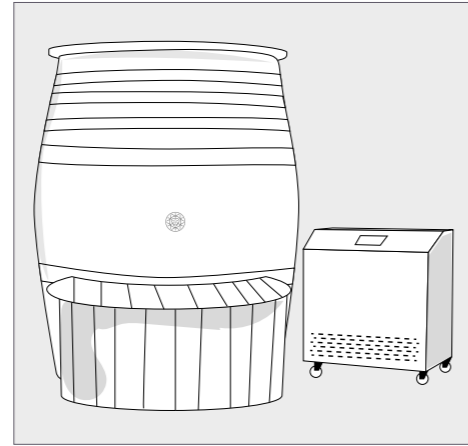

Step one

Place your barrel and chiller into the final position you want them in. Remembering that you will need good airflow for the chiller and access to the control panel. The unit weighs over 600Kg when full so it's best to get it in its forever home now.

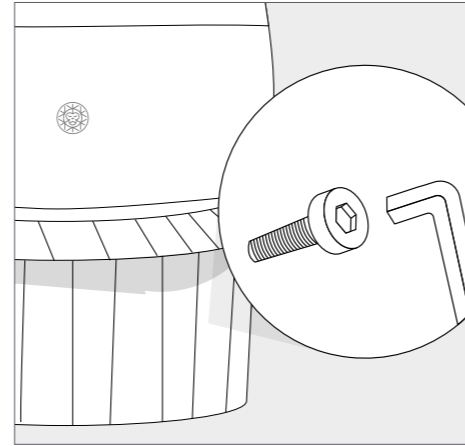

Step two

Attach the step to the barrel. Using the bolts provided, use an allen key to attach the bolts through the holes in the back of the step into the brackets that are mounted on the front of the barrel.

Getting Set Up

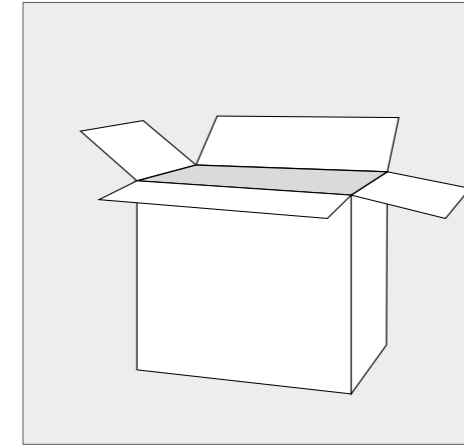

Step three

Remove the chiller from its packaging. Leave the power off at this point.

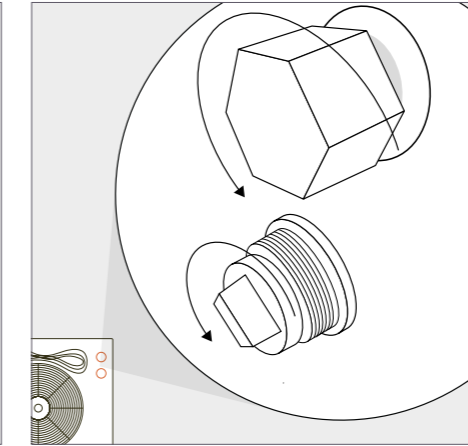

Step four

Remove the two white stopper fittings on the back of the chiller.

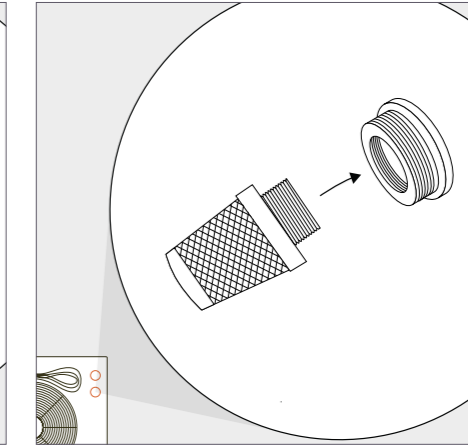

Step five

Screw the hose filter into the lower fitting on the chiller.

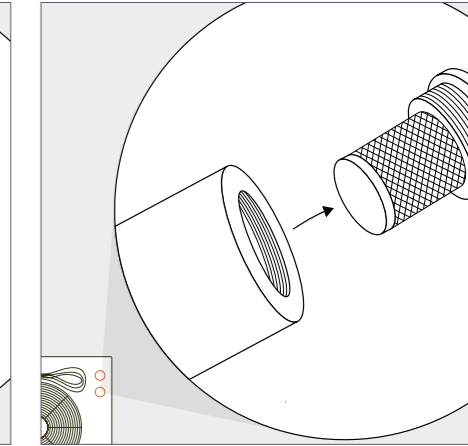

Step six

Screw the hose adaptor over the filter and onto the lower fitting on the chiller.

Getting Set Up

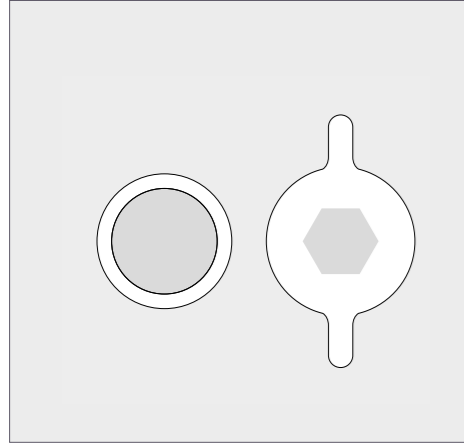

Step seven

Ensure there is an O ring in the end of each pipe (4 in total), if not use the spares provided.

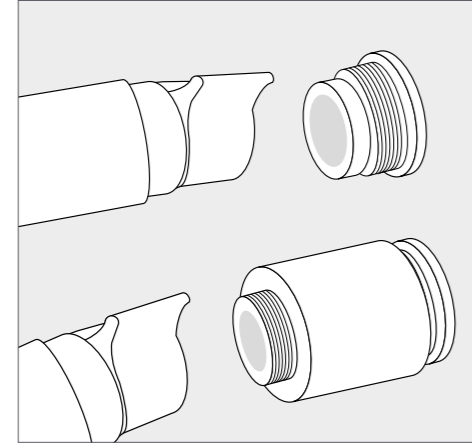

Step eight

Attach the end of the pipes to the fittings on the back of the chiller.

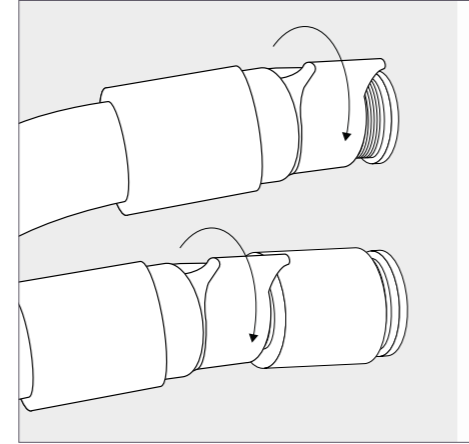

Step nine

Just screw them on and twist until secure.

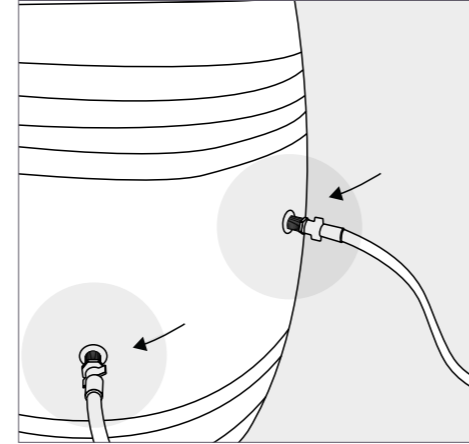

Step ten

Now attach both pipes to each of the holes on the barrel:

- Top hose to top fittings
- Bottom hose to bottom fittings.

Getting Set Up

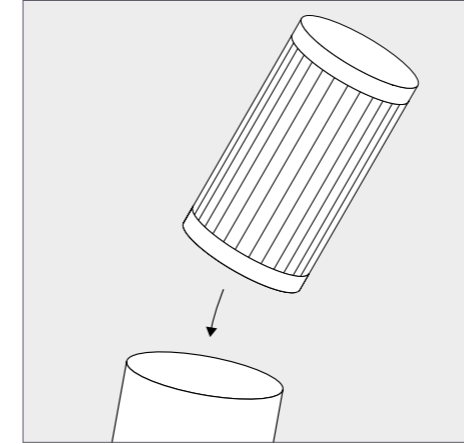

Step eleven

Fit the Filter. Unscrew the filter housing on the side of the chiller using the filter housing key, pop your filter in, screw it back in.

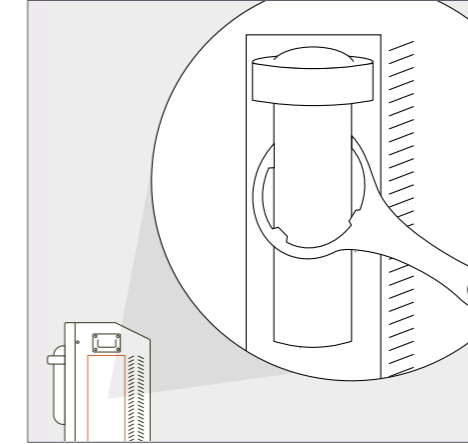

Step twelve

Using the filter housing key turn it by 1/8th for a snug fit without over tightening.

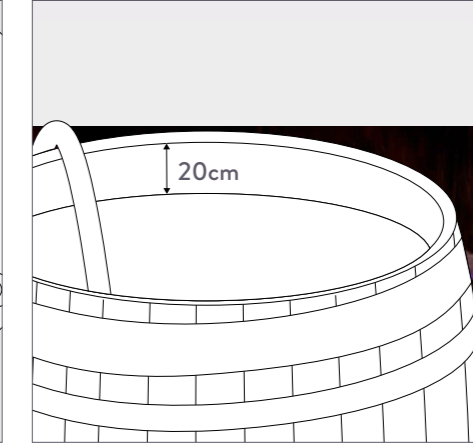

Step Thirteen

Now you can fill the barrel with water using a garden hose, fill to 20cm below the rim of the barrel with clean tap water.

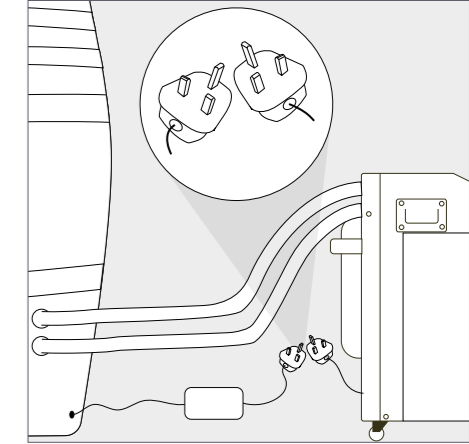

Step Fourteen

Plug in the light and the chiller - you are now ready to switch the chiller on and set it to your desired temperature!

Using the control panel

- 1 **Power on/off key:** Press for 1 second to power on/off: the software version number o1.X.(x represents numbers 1-9) will be displayed when the machine is switched on.
- 2 **Mode key:** Press for 3 seconds to convert temperature units.
- 3 **Set Key:** Press S and then press the up or down (5,6 keys) to adjust to the required temperature.
- 4 **Ozone key:** Press and hold S and then press W to adjust the ozone level function.
- 5 **Up arrow:** Used after pressing S to increase the temperature of the water.
- 6 **Down arrow:** Used after pressing S to reduce the temperature of the water.

- 7 **System Working Status:** Displays whether the chiller is cooling or heating.
- 8 **Defrost:** On means the machine is defrosting, Off means the machine is not defrosting.
- 9 **Water flow:** Displays the water flow, if there is no flow device installed, it will display 0.
- 10 **The flame icon** is displayed when heating
- 11 **The snowflake icon** is displayed when cooling

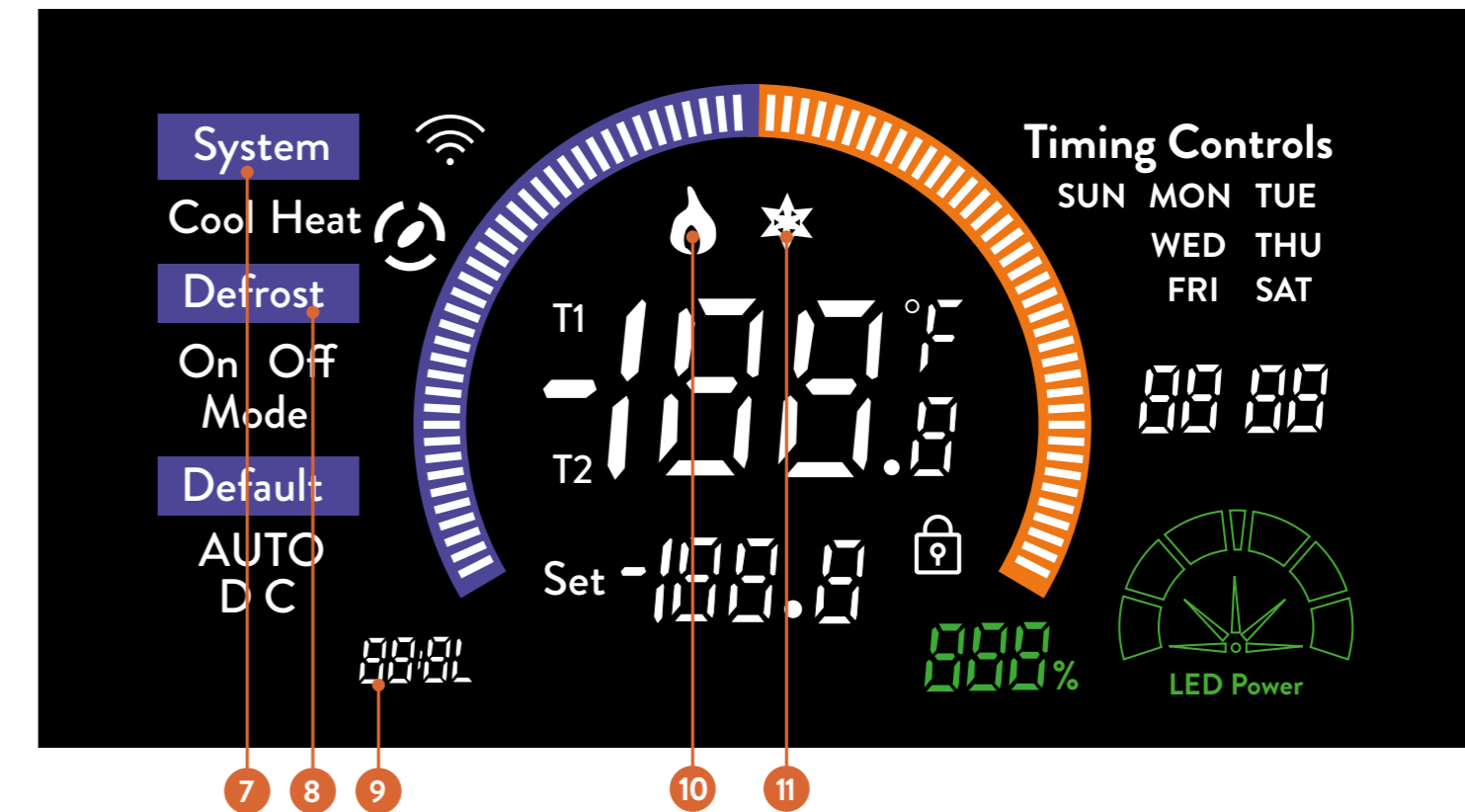
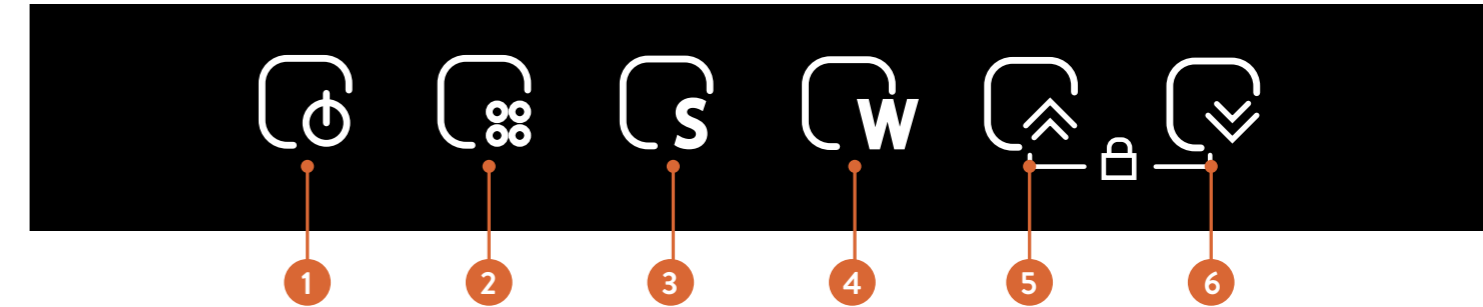



Keeping the water clean

- Clean the filters every 10 days.
- Change the water once a month.
- Set the ozone function at Low, Med or High.
- Use a residual cleaner such as Huwa-San.

Cleaning the filters and changing the water

Dependent on usage we recommend you clean the filter every 10 days and then do a full clean once a month. Here we describe the steps to change the water and clean the filters.

Make sure you switch off the power to the chiller before starting.



1 Drain the barrel using a submersible pump.



4 Flush any sediment or solid matter present in the filter bowl with running water.

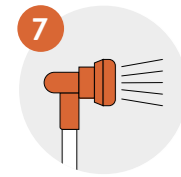

7 To clean the filter you have just removed you can run this under the hose until the water runs clear. We also recommend soaking the filter in a bucket of water with a small amount of Lo-Chlor filter cleaner & degreaser. Rinse well after soaking. This can then be left to dry for the next filter change.



2 Clean the hose filter by removing it from the back of the chiller and clearing any debris it has collected.

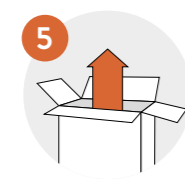

5 To fit a new cartridge, remove the cartridge from its packaging and ensure it does not pick up any contamination before fitting in the housing.



8 Clean the inside of the barrel with antibacterial wipes or an antibacterial spray and clean cloth. This will lengthen the life of the water on the next fill by making sure any bacteria is cleaned away. Don't forget to clean underneath the step as bacteria can lurk here!



3 Unscrew the filter housing, using the spanner provided to gently twist it loose.

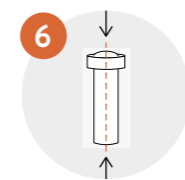

6 Seat the cartridge into the filter housing and check it has been correctly aligned before locating it back into place and gently tightening with the spanner.



9 Refill the barrel using the hosepipe . Switch on as usual and set your desired temperature.



Cleaning the filters without draining the water

When you clean the filter every 10 days you can do a quick filter change without draining the water.

- Switch off the chiller.
- Turn the blue taps into the off position so that they are no longer in line with the pipe.
- Remove the hoses from the back of the chiller and place into the barrel.
- Follow steps 2 - 7 to replace the filter.
- Reattach the hoses onto the chiller.
- Turn the blue taps in line with the pipe to allow the water to flow.
- Switch the chiller on.

You will find your own cleaning protocol that works for you, the recommendations are based on an average household use and don't take into account other factors such as frequency of use and body lotions in the water. When you begin using the barrel, you will soon find the optimum number of days until your next filter change and then your next water change. As a rule of thumb, if the water is murky, it means that you have gone past the date for changing your filter. You can use residual cleaners in the barrel such as Huwa-San to extend the time between filter/water changes. Problems can occur if the cleaning protocol is not followed:

Problem:

The chiller is noisy / has stopped cooling. This indicates that water cannot move freely and the pump is straining to pull water through, you will see a reduced water flow rate on the control panel. A normal flow rate is between 17 and 20L per minute.

Solution:

- Check the filters.
- Check that the hose filter on the inlet pipe on the chiller is clear. If the hose filter is clogged with dirt this will reduce the flow rate.
- Check if the main filter on the side of the unit needs changing or cleaning.

Problem:

The water is murky.

Solution :

- Change your cleaning protocol.
- Decrease the amount of days between filter/water changes.
- Introduce a residual cleaner.
- Keep the lid on to prevent debris entering the water.

Using the ozone cleaning function

The ozonator function aids in oxidising organic substances, removing the need for chemicals or residual water treatment. It breaks down viruses, bacteria and other organic material such as dead skin. Ozone is a powerful oxidizer of scale, scum and biofilm.

The ozone travels through an air line connected to a the water pump. The water and the ozone are then pushed into through the pipes into the barrel. Once the ozone is in contact with the water in your chiller, it will work to kill bacteria, contaminants and other waste.

The chiller has 3 different ozone functions and you can select which one you use based on the levels of use of the barrel.

Setting	Ozone function	Usage
1	Ozone runs for 1 mins every 15 minutes.	Low use: 1 person, a couple of times per week.
2	Ozone runs for 2 mins every 15 minutes.	Medium use: 1-2 people, most days.
3	Ozone runs for 3 mins every 15 minutes.	High use: More than 2 people, used multiple times per day.

To set the ozone function functionality:

Press and hold “S”, then Press “W”.

Press the Up arrow or Down arrow to select setting 1, 2 or 3.

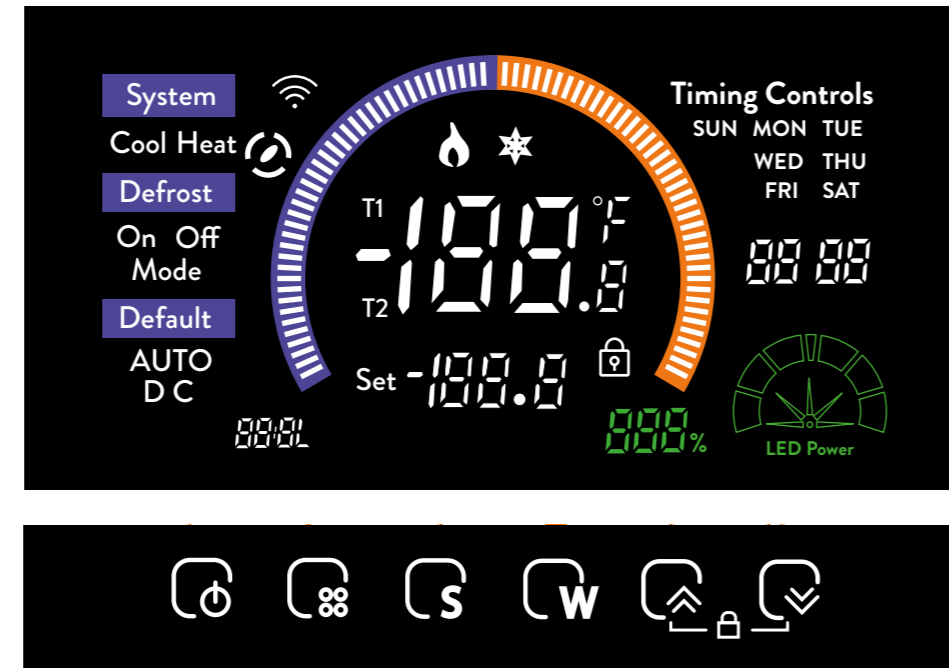

Fault codes & solutions

Error Code	Alarm	Reason	Solution	Machine Status
IN	NO	Loose connection to panel.	Re-plug both ends of the cable. Contact Brass Monkey.	Will not work.
HH	YES	The water temperature is higher than the upper limit temperature.	If there is a difference between the lower water temperature and the displayed water temperature, the water temperature sensor is faulty. Contact Brass Monkey.	Will not work.
FL	YES	No water flow.	No water flow: the water pump is broken or stuck, and the waterway is blocked. Contact Brass Monkey.	Press and hold the mode button + setting button for 5 seconds to force the alarm to stop.
FL	YES	Too little water flow.	There may be a tube folded in the waterway, the water flow is smooth, or the waterway is not cleaned for too long, and the scale is blocked, flush it with an air gun. Contact Brass Monkey.	Press and hold the mode button + setting button for 5 seconds to force the alarm to stop.
CH1	YES	Bad Sensor (Green).	Replace the NTC1 temperature sensor, restart the machine after replacement. Contact Brass Monkey.	Will not work.
HEA	NO	Heating Failure - the machine will not heat but can still cool.	Contact Brass Monkey.	Cooling only.
ICE	YES	Water temperature No. below freezing point.	Turn off the machine, pour hot water into the barrel and heat it for 20 minutes, then turn it on again.	Press key 2 + key 3 at the same time for 3 seconds to forcibly cancel the alarm, and the machine will return to normal mode.
PA	NO	Sensor failure (Red).	Replacing the NTC3 temperature sensor. Contact Brass Monkey	Will work normally.
AA	NO	Temperature Sensor Failure	Replacing the NTC4 temperature sensor. Contact Brass Monkey.	Will work normally.

Maintaining the barrel

Your barrel is a thing of natural beauty, there is literally not another one the same. We took many weeks to prepare it for you, here's how to keep him (or her!) happy...

Positioning - The barrel is an outdoor product only. Aged oak is happiest in moderate temperatures and when the unit is filled with water to retain moisture levels. The ground under the barrel should be level and of solid construction - this is vital to ensure before filling.

Sunlight - We recommend always keeping the barrel under a degree of shade on hot days, whilst not critical it will help your barrel to last for years to come. This is more important in very hot climates where summer days repeatedly reach temperatures over 35°C. Direct sunlight and heat warms the wood, it's a natural product that expands and contracts, the aim is to minimise this flexing where possible.

Freezing weather - Being Scottish, the barrel will be happy on cold days, however please keep the water circulating (the chiller switched on), this is to prevent the water standing and freezing in the pipework between barrel and chiller

Exterior wood maintenance - the barrel is cleaned and sanded before an oil is applied. Reapply this every two years, we use Osmo natural woodstain.

Interior resin maintenance - the resin is applied once and will not need applying again for the life of the barrel. You can maintain the resin by never using or applying harsh chemicals in the water. This includes chlorine and other salts. We encourage the use of eco-friendly additives or cleaners such as hydrogen peroxide so long as not above 500ppm.

Removing debris - inside the barrel, the base will collect grit and debris from your feet. You can remove grit easiest with pump-action spa vacuum. Any debris, such as leaves, floating on the surface can be removed with a small net.

Storage - the barrel is happiest when filled with water as it retains moisture in the wood. If you decide to store the barrel empty for a period then move to a cool and shaded location. Upon refill it's possible the wood will contract and tiny leaks will occur, these will self heal a day after refilling as the wood expands again.

Chiller technical data

Voltage	220-240VAC 50/60Hz
Dimension (LxWxH)	510x400x560MM
Weight	35 KG
Warranty	1 Year
Power	710W
Working Temperature Range	3 to 42 °c
Cooling capacity	1770W
Cooling type	Cooled Water Circulating
Refrigerant	R410
Model Number	SY-08-HC/OC (YC-2800W)
Compressor power	605W
Tank volume	500L

Estimated Cooling Times to 3-5°C

Volume	Time
< 50L	0.37H
50 - 100L	1.1H
100 - 200L	2.2H
200 - 500L	5.5H

We are here for you

If you have any questions or require technical support
you can get in touch with us by the following means:

Email: support@brassmonkey.co.uk

Call us: 0113 526 7255

Raise a ticket in your online account



BRASS MONKEY